

Instruction Manual

-30kV DC Insulation Tester MIT30

Catalog No. MIT30



High Voltage Equipment

**THIS EQUIPMENT PRODUCES
INSTANTANEOUSLY LETHAL VOLTAGE**

Please read carefully before operating
Safety is the responsibility of the user

Megger [®]

Valley Forge Corporate Center
2621 Van Buren Avenue
Norristown, PA 19403-2329
U.S.A.

610-676-8500

www.megger.com

**-30kV DC Insulation Tester
MIT30**

Catalog No. MIT30

Instruction Manual

Copyright© 2009 by Megger. All rights reserved.

The information presented in this manual is believed to be adequate for the intended use of the product. If the product or its individual instruments are used for purposes other than those specified herein, confirmation of their validity and suitability must be obtained from Megger. Refer to the warranty information below. Specifications are subject to change without notice.

WARRANTY

Products supplied by Megger are warranted against defects in material and workmanship for a period of 12 months following shipment. Our liability is specifically limited to replacing or repairing, at our option, defective equipment. Equipment returned to the factory for repair must be shipped prepaid and insured. Contact your MEGGER representative for instructions and a return authorization (RA) number. Please indicate all pertinent information, including problem symptoms. Also specify the serial number and the catalog number of the unit. This warranty does not include batteries, lamps or other expendable items, where the original manufacturer's warranty shall apply. We make no other warranty. The warranty is void in the event of abuse (failure to follow recommended operating procedures) or failure by the customer to perform specific maintenance as indicated in this manual.

Megger.

Valley Forge Corporate Center
2621 Van Buren Avenue
Norristown, PA 19403-2329
U.S.A.

610-676-8500

www.megger.com

Table of Contents

1 INTRODUCTION	1
How to Use this Manual.....	1
2 SAFETY PRECAUTIONS.....	3
3 RECEIVING INSTRUCTIONS.....	7
4 SPECIFICATIONS.....	9
Input.....	9
Output.....	9
Control.....	10
Safety	11
Physical	11
Environmental	12
Regulatory Compliance.....	12
5 DESCRIPTION.....	13
6 SETTING UP.....	15
Selection of Location	15
Clearances	16
Connections Procedure	17
7 OPERATION	19
TEST PROCEDURE	19
USE OF GUARD.....	21
8 ROUTINE MAINTENANCE	23
Before Each Use.....	23
Inspection and Maintenance Procedure.....	24
Calibration Procedure	25
9 THEORY OF OPERATION & TROUBLESHOOTING	29
10 NOMENCLATURE.....	33
Field Replaceable and Recommended Spare Parts.....	33

Megger.

1

INTRODUCTION

This instruction manual is intended as a guide to the operation of the MIT30. The instructions and suggestions provided in this manual anticipate the normal use of the insulation tester for testing electrical insulation systems.

In the normal course of testing, a specimen or system is subjected to high DC voltage. The resulting current and the manner in which the current varies with time, provides data that indicates the condition of the specimen or system insulation.

How to Use this Manual

Typographic Conventions

- Numbered lists show procedural steps.
- Bullets list items and options.

Warning and Caution Notices

Warning and caution notices are used throughout this manual where applicable. These notices

appear in the format shown below and are defined as follows:



WARNING!

Warning, as used in this manual, is defined as a condition or practice which could result in personal injury or loss of life.



CAUTION

Caution, as used in this manual, is defined as a condition or practice which could result in damage to or destruction of the equipment or apparatus under test.

NOTES: Provide important information

2

SAFETY PRECAUTIONS

SAFETY IS THE RESPONSIBILITY OF THE USER

The test set and the equipment to which it is connected is a source of high-voltage electrical energy. All persons performing or assisting in the tests must use all practical safety precautions to prevent contact with energized parts of the test equipment and associated circuits. Persons actually engaged in the test must stand clear of all parts of the complete high voltage circuit unless the test set is de-energized and all parts of the test circuit are grounded. Persons not directly associated with the work must be kept away from the test activities by suitable barriers, barricades or warnings.

The test set must be connected to a reliable local ground to prevent possible shock danger to the operator. Since the energized test setup may induce a static charge on nearby insulated objects, including people, all insulated objects must be grounded or kept at least three feet (0.91 meters) from the energized structure.



WARNING
Never connect the test set to energized equipment or use the test set in an explosive atmosphere.

All apparatus to be tested should be bonded to ground except during the actual test. Test connections should be made with the ground bonds in place.

NOTE: Please note that even isolated conductors may develop static charge due to nearby electrical fields.

At the completion of a test, after the power source has been shut down and the test set kV meter reads zero, all energized parts of the test setup **MUST** be short circuited by means of a safety grounding/discharge rod or “hot stick.” Ground bonds should then be applied to the equipment that was tested. These should be left in place until access to the equipment is again required.

If the test set is operated in accordance with the safety precautions noted above and if all grounds are correctly made, rubber gloves are not necessary. That being so stated, please observe all governmental, local, work regulations as applicable with regard to operating or working in proximity to high voltage electrical energy. Ensure the use of all PPE (Personal Protective

SAFETY PRECAUTIONS

Equipment) as required by local regulation or company Electrical Safety Rules. As a routine safety procedure however, rubber safety gloves should be worn when making connections to any high voltage terminals. Some users are required by work rules to wear safety gloves when manipulating the controls; Megger considers this an excellent safety practice.

WARNING

Do NOT use the MIT30 test set for any purpose not described in this instruction manual and do not use accessory items for any purpose except with the specified equipment.



Before operating read and follow the instruction manual.

Equipment operators must read this manual in its entirety prior to energizing the MIT30. Megger strongly recommends that users conduct a mock test, using a test object to familiarize themselves with the equipment as well as to assure proper equipment operation prior to conducting an actual test.

WARNING

Equipment operators should open the case pressure equalization valve if large changes in ambient air pressure (altitude) are expected. The valve should be closed at all other times to prevent moisture and debris infiltration.



Megger.

Megger.

3

RECEIVING INSTRUCTIONS

When your instrument arrives, check the equipment received against the packing list to ensure that all materials are present. If there is a discrepancy please contact us at:

Megger

Valley Forge Corporate Center

2621 Van Buren Avenue

Norristown, PA 19403-2329 U.S.A.

Phone: 610-676-8500

Fax: 610-676-8625

Email: VF Customer SVC Dept

(case sensitive, no extension)

Web: *www.megger.com*

Examine the instrument for damage received in transit. If any damage is discovered, file a claim with the carrier at once and notify Megger or it's nearest authorized sales representative giving a detailed description of the damage observed.

This instrument has been thoroughly tested and inspected to meet rigid inspection specifications before being shipped. It is ready for use when set up, as indicated in Sections 6 and 7 of this manual.

Megger.

Megger.

4

SPECIFICATIONS

INPUT

Voltage:	85 – 264 VAC, 110 – 350 VDC
Frequency:	DC, 47 – 440 Hz
Maximum:	35 VA
Fusing:	Double Pole 5 x 20mm ceramic 3.15A slow blow fuse, 500 VAC
Power Inlet:	C14 acc. to IEC/EN 60320-1

OUTPUT

Voltage:	0 to -30 kV
Maximum Current:	300 μ A
Peak - Peak Ripple:	< 0.4%
Line Regulation:	0.03%
Load regulation:	0.001%

Stored energy:	< 50 mJ
Test Connection:	3 meter (9.8 feet) triaxial cable (-HV, guard and current sense) terminated with crocodile clips.

CONTROL

- Mains ON/OFF switch integrated with power inlet and fuse holder
- High Voltage power supply control with integrated Zero-Start switch
- High Voltage warning lamp (RED) incorporated into high voltage shut-off switch
- Ready lamp (GREEN) incorporated into high voltage on switch
- Voltmeter: Backlit LCD, 10V resolution, $\pm 1.5\%$ full scale accuracy
- Current meter: Backlit LCD, 100nA resolution, ± 300 nA accuracy
- Over Current trip: Single-Turn Pot, 0 – 120% of rated output
- Audio Ionization Indicator with volume control and integrated switch.

SAFETY

- 33M Ω Fail-Safe Internal Discharge Switch
- Integrated Zero-Start switch
- High Voltage warning lamp
- High strength plastic case
- Cable interlock
- Air-transport pressure relief valve

PHYSICAL

Length: 360 mm (14.2 in)

Width: 304 mm (12 in)

Depth: 194 mm (7.6 in)

Weight: 8 kg (17.6 lbs)

- Impact resistant, rotary molded plastic case
- Lightweight Aluminum front panel
- Carrying handle
- Air transport pressure relief valve

ENVIRONMENTAL

IP rating:	67 with case closed for transport (as defined by Standard 81-41/STANAG 4280) 52 when in use
Operating temperature:	-10C to 55C (14 F to 131F)
Storage temperature:	-20C to 70C (-4 F to 158 F)
Humidity:	0 – 90% (non-condensing)
Maximum Altitude (Full rating)	1600m (MSL) (5200 ft MSL)

REGULATORY COMPLIANCE

EMC:	Compliant to IEC 61326, Table 1, criterion A for immunity Compliant to IEC 61326, Table 4, class B for emissions
Safety:	Compliant to IEC 61010-1 2001

5

DESCRIPTION

This Insulation test set measures the electrical quantities of applied voltage and the resultant current in the apparatus to which it is connected. Designed for field use, the test set is built into a durable, rotary molded, impact resistant case with carrying strap.

The test set consists of a variable DC power supply with metering of the output voltage and current passing between the high voltage terminal and ground (CURRENT SENSE).

Megger.

Megger.

6

SETTING UP

Test controls and terminals are identified in Section 6. The following steps are listed as a general guide for setting up the insulation tester.

Before setting up the equipment make sure you have read and understand Section 2 of this manual entitled SAFETY. Working with due regard to safety, identify the terminal of the apparatus to be tested.

Define the type of test required

Setup barriers or use other means to keep unauthorized personnel away from all high voltage terminals of the complete test arrangement.

SELECTION OF LOCATION

1. The operating area must be as dry as possible.
2. The operator of the test set must be able to conduct the test without being exposed to traffic hazard; the operator must have free access to all controls and be able to read the

meters and panel markings easily without approaching the energized high-voltage terminals.

CLEARANCES

1. Be sure adequate clearances are maintained between energized conductors and ground to prevent arc over. Such accidental arc-overs may create a safety hazard or damage the equipment being tested. The position of the exposed conductors with respect to ground can often be maintained in place with clean, dry nylon rope. The chart below indicates some recommended clearances that will limit the danger of static voltages being induced or developed on nearby insulated objects, including people.

TEST VOLTAGE	DIRECT AIR PATH STRIKE DISTANCE	CREEP PATH ALONG NYLON ROPE	MINIMUM CLEARANCE TO PREVENT STATIC CHARGING
30 kV	> 3.0 cm (1.18 in)	> 8 cm (3.15 in)	1.1 m (43.3 in)

2. After completion, make a careful review of the test setup. Tests of the attached apparatus can then be performed.

CONNECTION PROCEDURE

1. Ground and bond all terminals of the test object to a known, good earth ground point.
2. With the test set switch off, connect the power cord to the mains supply.

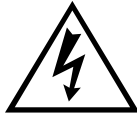

WARNING

The third wire in the input power line is the system ground. Operator and equipment safety depend on this connection being made to a good ground.

3. Connect BLUE guard lead to drain leakage currents. (See USE OF GUARD section)
4. Connect BLACK current sense lead to the low potential end of the test object.
5. Connect RED output cable clip to the high voltage terminal of the apparatus to be tested

Megger.

Megger.

7

OPERATION

When the test set and apparatus to be tested are set up as indicated in Section 6, the equipment can be energized and the required tests run by following the steps given below.

<p><i>Note:</i> Before operating the test set, read Section 2 of this manual and ensure that all appropriate safety precautions are observed.</p>

TEST PROCEDURE

1. Complete connection procedure as outlined in Section 6.
2. Remove all safety grounds from the apparatus to be tested
3. Close the mains switch, the power indicator will illuminate.
4. Set the overcurrent trip to the desired trip level.
5. Set the ionization volume to the desired level.

Megger.

6. Rotate the voltage control to 0.0 to engage the zero-start interlock. Ensure the locking collar is not engaged.
7. Depress the GREEN illuminated button on the panel to engage the HV



WARNING
HIGH VOLTAGE PRESENT

8. When the RED button illuminates, rotate the voltage control knob until the desired voltage is attained.

After Testing Is Completed -

9. Rotate the voltage control to reduce the voltage to zero.
10. Press the red button to shut off the HV and discharge the sample.

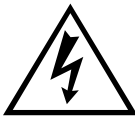

WARNING
Ensure that voltmeter reads less than 0.03kV before proceeding to the next step.

11. Open the mains switch.



WARNING

Use an external safety grounding/discharge rod or “hot stick” to prove that the system has been de-energized prior to handling.

12. Apply safety grounds to the apparatus
13. If desired, disconnect the HV clip from the apparatus

Notes:

- *If cable interlock LED is illuminated, check the cable connections*
- *Connect the guard terminal to bypass any undesired currents (see the following paragraphs regarding use of the guard terminal).*
- *If the guard terminal is connected alone no current will be displayed*
- *If during the test the over current trip is triggered, you must first reset the HV by rotating the voltage control knob to zero, and then pressing the over current reset button.*

USE OF GUARD

Occasionally when measuring apparatus, the leakage resistance of interest is masked by a parallel path. Such a situation is often encountered when measuring the leakage current of a cable. In the practical situation, the value of

resistance along the leakage path from the conductor over the surface of the termination may be less than that within the major length of the cable. Under such conditions the guard feature of the test set is useful in excluding the leakage of the surface path from the measurement. This is easily accomplished by forming an electrode by wrapping a bare wire around the outer surface of the termination. This wire electrode, which will intercept the surface current, must be connected to the test set guard terminal (BLUE crocodile clip).

The same guard principle can be used on other apparatus where a suitable intercepting electrode can be added on a temporary basis.

8

ROUTINE MAINTENANCE

As field service subjects high voltage test equipment to sometimes difficult environmental conditions, a vigilant visual inspection program should be employed.

BEFORE EACH USE

- Inspect case for visible signs of damage
- Inspect meter faces for visible signs of damage
- Inspect output cable. The cable should not show any radical changes in geometry. Connectors should be free of distortion and burrs. The outer jacket should be clean and free of cuts.
- Inspect power cable. It is vitally important that the ground pin is mechanically sound. The cable should be free of cuts or radical changes in geometry.

There are no user serviceable parts or assemblies contained within the MIT30.

INSPECTION AND MAINTENANCE PROCEDURE

Proceed according to the steps below:

1. Visually inspect the unit case, noting that hinges and case locks function properly
2. Check for breaks and or cracks in the case or lid
3. Check that the cable bag remains firmly affixed to the lid
4. Remove the cables from the bag and set them aside.
5. Take note of the air transport valve; that it rotates smoothly and cinches down firmly.
6. Note the condition of the carry handle and case feet.
7. Wipe the exterior of the case with a damp cloth; then dry with a clean dry cloth. Detergents and special cleaning agents are neither required nor necessary.
8. Retrieve the cable set aside earlier, inspect the cables looking for damaged insulation or frayed jackets. Pay special attention to the HV output cable, check the condition of the crocodile clip, and ensure that the spring tension is sufficient and not damaged. The

ROUTINE MAINTENANCE

clip should be smooth and clean. If the unjacketed portion of the HV cable is dusty, wipe it down with a clean dry lint free cloth.

9. Check that all knobs rotate smoothly throughout their entire range, that all knobs are firmly affixed, and in serviceable condition with no cracks. Pay special attention to the HV voltage control knob with its locking feature. Ensure that the lock engages and disengages smoothly.

CALIBRATION PROCEDURE

REQUIRED EQUIPMENT

30 kV range voltmeter, 0.5% F.S. accuracy,
NIST traceable

300 μ A ammeter, 0.5% F.S. accuracy,
NIST traceable

100 M Ω (+/- 30%), ≥ 15 W, ≥ 30 kV test load

VOLTMETER CALIBRATION

1. Read and fully understand instruction manual.
2. Remove top panel screws.
3. Separate top panel from chassis. Refer to Figures 5A and 5B.

Megger.

4. Place unit sections on non-conductive (at >30 kV) surface.
5. Connect unit to mains.
6. Connect output across 30 kV calibration voltmeter.
7. Energize unit.
8. Engage high voltage (DANGER! HIGH VOLTAGE PRESENT!).
9. Turn the voltage control knob to 10.0.
10. Adjust R38 on control PCB until -30.00 kV is read on the calibration voltmeter.
11. Adjust R40 until the MIT30 voltmeter reads -30.00.
12. Disengage high voltage.
13. De-energize unit. Restore unit to case.

AMMETER CALIBRATION

1. Read and fully understand instruction manual
2. Connect unit across test load.
3. Connect ammeter in series with low potential lead of test load and current sense lead of unit.

ROUTINE MAINTENCE

4. Energize unit.
5. Engage high voltage (DANGER! HIGH VOLTAGE PRESENT!).
6. Raise MIT30 output voltage until 300 μ A is displayed or the 30 kV limit is achieved.
7. Read current measured through calibration ammeter.
8. Read current measured by on-board ammeter.
9. If the difference between the calibration ammeter and the on board ammeter is greater than 1%, replace the control PCB.
10. Disengage high voltage.
11. De-energize unit.

**RECOMMENDED CALIBRATION
INTERVAL IS 18 MONTHS.**

Megger.

Megger.

9

THEORY OF OPERATION AND TROUBLESHOOTING

WARNING

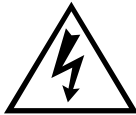

Only personnel that have been trained and qualified to repair high voltage test equipment should attempt any of the following repair and/or calibration procedures.

The MIT30 is an adjustable, high voltage DC power supply, capable of sourcing 330 μA . Output voltage and current is displayed on high contrast, liquid crystal displays. The MIT30 has an active over current trip that can be adjusted between 3% and 120% of full rated current.

Input power is connected to the input power module via a standard C-14 IEC 60320-1 connector. If the power source frequency is between 47 and 440 Hz and the voltage is between 85 VAC and 265 VAC, the source should be considered valid. Additionally, DC

sources with voltages between 110 VDC and 350 VDC can be used.

The input power is fed through 3.15A ceramic-body fuses and the mains switch to a 24 VDC power supply. The power supply output is directly fed to the control PCB where it is also converted to +15 VDC and +5 VDC. All power bussing is done on the control PCB.

When high voltage is desired, the green front panel button is activated. If the zero-start and cable interlocks are satisfied and the over current sensor is not tripped, a relay on the control board enables the high voltage power supply and opens the discharge switch. If the cable interlock or the over current sensor is activated during operation, the high voltage power supply is immediately disabled and the discharge switch is closed. The discharge switch is ballasted with a 33 M Ω resistor.

As mentioned above, the MIT30 indicates voltage, current and has an audible ionization indicator. Voltage measurement is accomplished through a highly protected, 2 G Ω input impedance circuit. The current is measured across a heavily protected 1 k Ω shunt. Ionization is detected by filtering the output voltage through a series of filters, the output of which is fed to an audio amplifier.

OPERATION/TROUBLESHOOTING

Troubleshooting Chart



Figure 1

Megger.

Megger.

10

NOMENCLATURE

Field Replaceable and Recommended Spare Parts

Due to the size constraints of the MIT30 design, advanced polymeric insulation systems are required. As a result, the only field replaceable components in the system are the following:

Description	Megger P/N
Fuse, 5x20 mm, ceramic, SB*, ▼	90001-269
Control Power LED*	36310-1
Cable Interlock LED*	36258-1
Over-current Trip LED	36258
Over-current Trip Reset Switch*	37282
Ionization Audio Control Potentiometer	37259
Voltage Control Potentiometer	37252
Output Cable*	1000-921
Voltmeter*	1001-116
Ammeter*	1001-117
Control PCB*	37264
HV Engage Switch (GREEN)	37276-2
HV Disengage Switch (RED)*	37276-1
+24 VDC Power Supply*	90000-755
*Recommended spares kit	
▼Should be replaced in pairs	

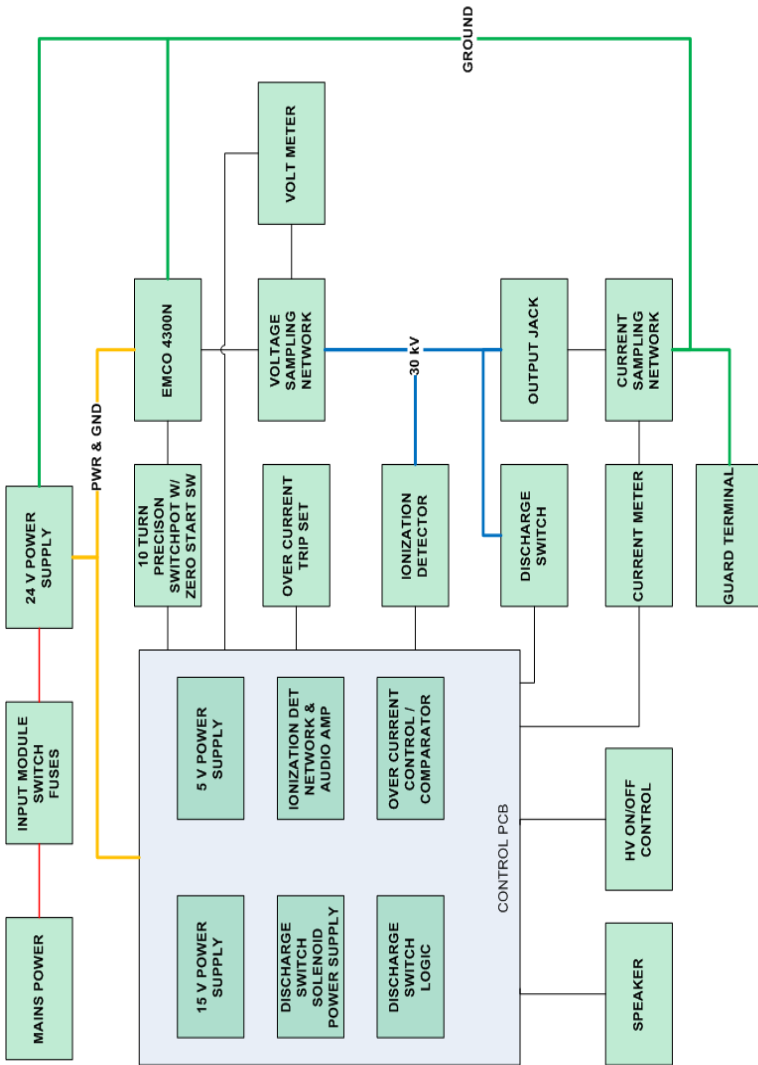

Figure 2

NOMENCLATURE

This page intentionally left blank.

Megger.

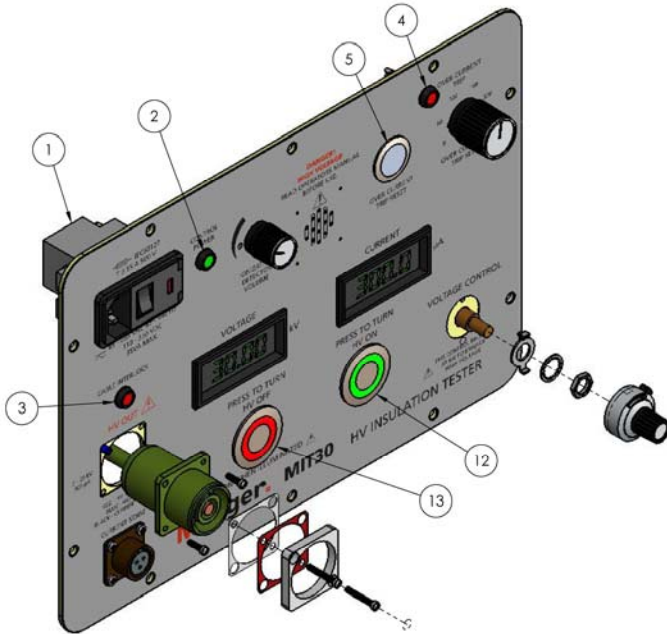

Figure 3

ITEM NO.	PART NO.	DESCRIPTION	QTY
1	90001-269	Fuse, 5x20 mm, ceramic, SB*, ▼	2
2	36258-1	Control Power LED* (GREEN)	1
3	36258	Cable Interlock LED* (RED)	1
4	36258	Over-current Trip LED (RED)	1
5	37282	Over-current Trip Reset Switch*	1
6	37259	Ionization Audio Control Potentiometer	1
7	37252	Voltage Control Potentiometer	1
8	1000-921	Output Cable*	1
9	1001-116	Voltmeter*	1
10	1001-117	Ammeter*	1
12	37276-2	HV Engage Switch (GREEN)	1
13	37276-1	HV Disengage Switch (RED)*	1
*Recommended spares kit		▼ Should be replaced in pairs	

NOMENCLATURE

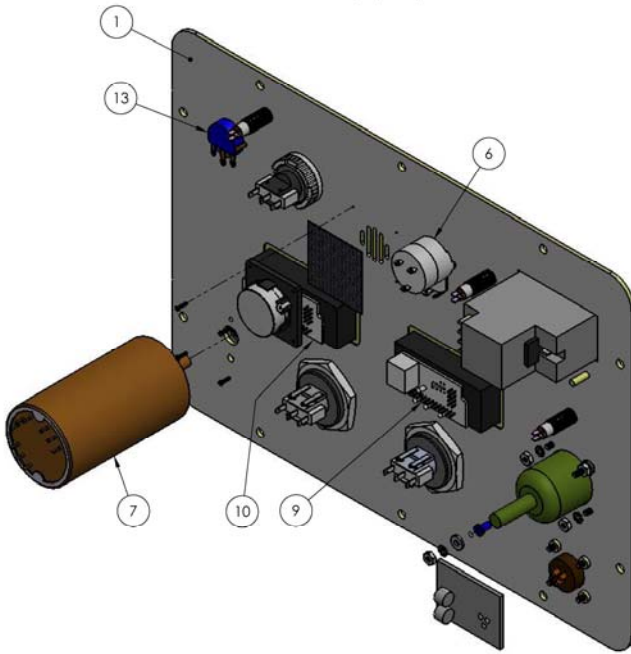

Figure 4

Megger.

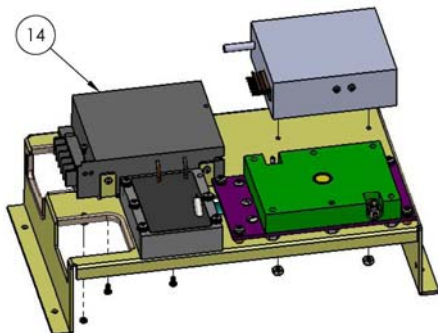

Figure 5A

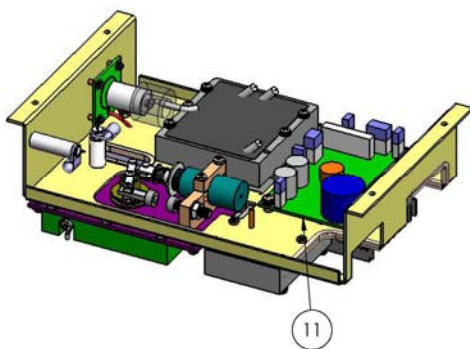

Figure 5B

ITEM NO.	PART NO.	DESCRIPTION	QTY
11	37264	Control PCB*	1
14	90000-755	+24 VDC Power Supply*	1

*Recommended spares kit ▼ Should be replaced in pairs